

W+ for pharmaceutical processes

CENTRIFUGAL PUMP

FORM NO.: L453146UK REVISION: 10/2012

READ AND UNDERSTAND THIS MANUAL PRIOR TO OPERATING OR SERVICING THIS PRODUCT.



Table of contents	Page
1. Dimensions - W+ pump with AP1-valve	3
1.1 Adjustable Feet - Centre height 350 mm	3
1.2 Bracket Type A (Standard)	4
1.3 Bracket Type B (Standard)	4
2. Spare Parts - W+ pump with AP1-valve	5
2.1 Overview	6
2.2 Impeller	6
2.3 Shaft Seal	7
2.4 Adjustable Feet Motor 90-132	8
2.5 Adjustable Feet Motor 160-200	9

This W+ pump type with AP1 aseptic diaphragm drain valve has been developed for pharmaceutical processes.

All product-wetted parts are 3.1 certified according to DIN EN 10204. Cast material is not applied.

All parts in contact with the product have a surface roughness of $Ra < 0,5 \mu m$ which complies with the requirements of the relevant 3-A Sanitary Standards.

Pump types: W+50/8, W+55/35, W+55/60, W+70/40

Valve types: Hand-operated, air/spring actuated and air/spring actuated with proximity switch.

1. Dimensions - W+ pump with AP1-valve

1.1 Adjustable Feet - Centre height 350 mm

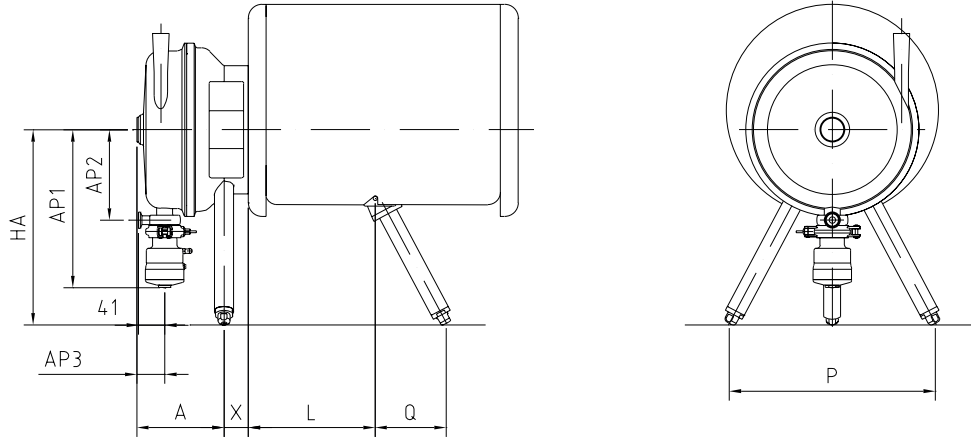
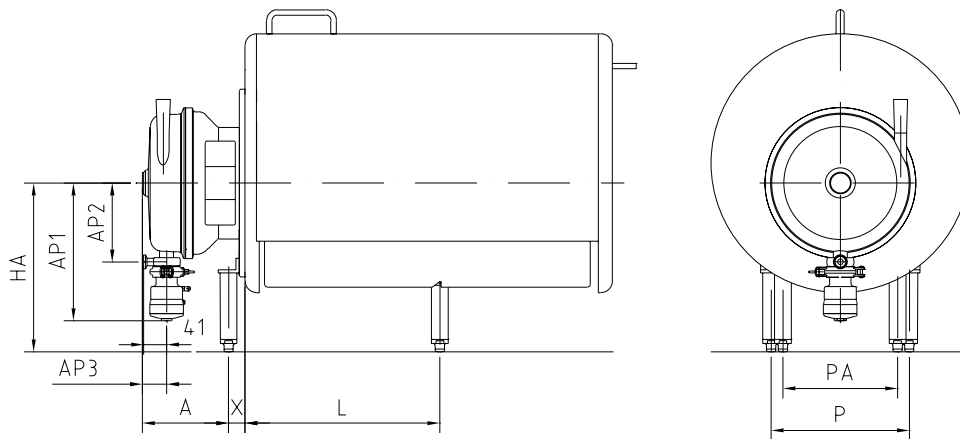
TG. 1 Motor 80-132

TG. 2 Motor 160M-200L

TG.		W+ 50/8	W+ 55/35	W+ 55/60	W+ 70/40	
	AP1	245	253	253	273	
	AP2	155	163	163	183	
	AP3	39	70	73	58	
1	A	141	174	182	151	
2			235	243	238	
1	X	39	39	39	67	
2			31	31	35	
80-132	1	HA	350	350	350	
160	2			350	350	
180					350	350
200					350	350

	Motor										
	TG. 1						TG. 2				
	90S	90L	100L	112M	132S	132M	160M	160L	180M	180L	200L
P	372	372	372	372	372	372	254	254	279	279	318
PA							222	222	222	222	222
Q	132	132	127	120	110	110					
L											
W+50/8											
W+55/35	156	181	203	210	252	290	318	362			
W+55/60											362
W+70/40											

1. Dimensions - W+ pump with AP1-valve

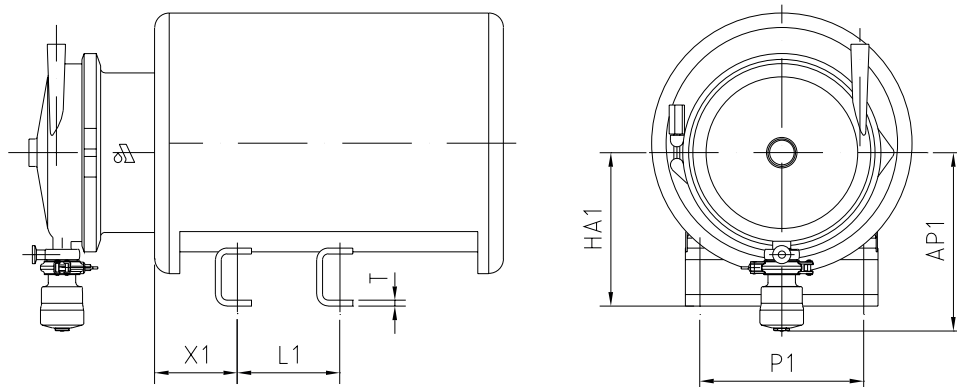
1.2 Bracket Type A (Standard)



1.3 Bracket Type B (Standard)

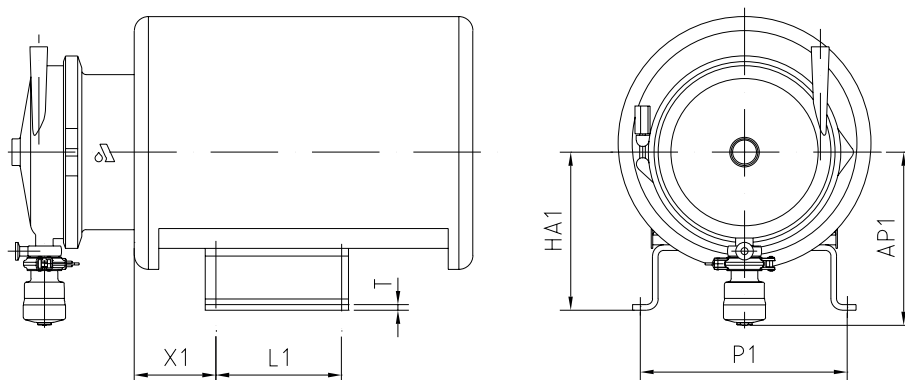

ATTENTION: AP1 > HA1 - consider when assembling ! (Dimensions AP1 see page 3)

Bracket		Motor										
		90S	90L	100L	112M	132S	132M	160M	160L	180M	180L	200L
A	X1	56	56	63	70	112	112	108	108	121	121	158
	B	L1	100	125	140	140	140	278	210	254	241	279
125			178				254		279			
A	T	6	6	6	6	6	6	6	6	6	6	8
B												10
B	P1	140	140	160	190	216	216	254	254	279	279	318
	PA1	216	216	236	266	292	292	358	358	379	379	432
A	HA1	170	170	180	192	212	212	240	240	260	260	280
B												

2. Spare Parts - W+ pump with AP1-valve

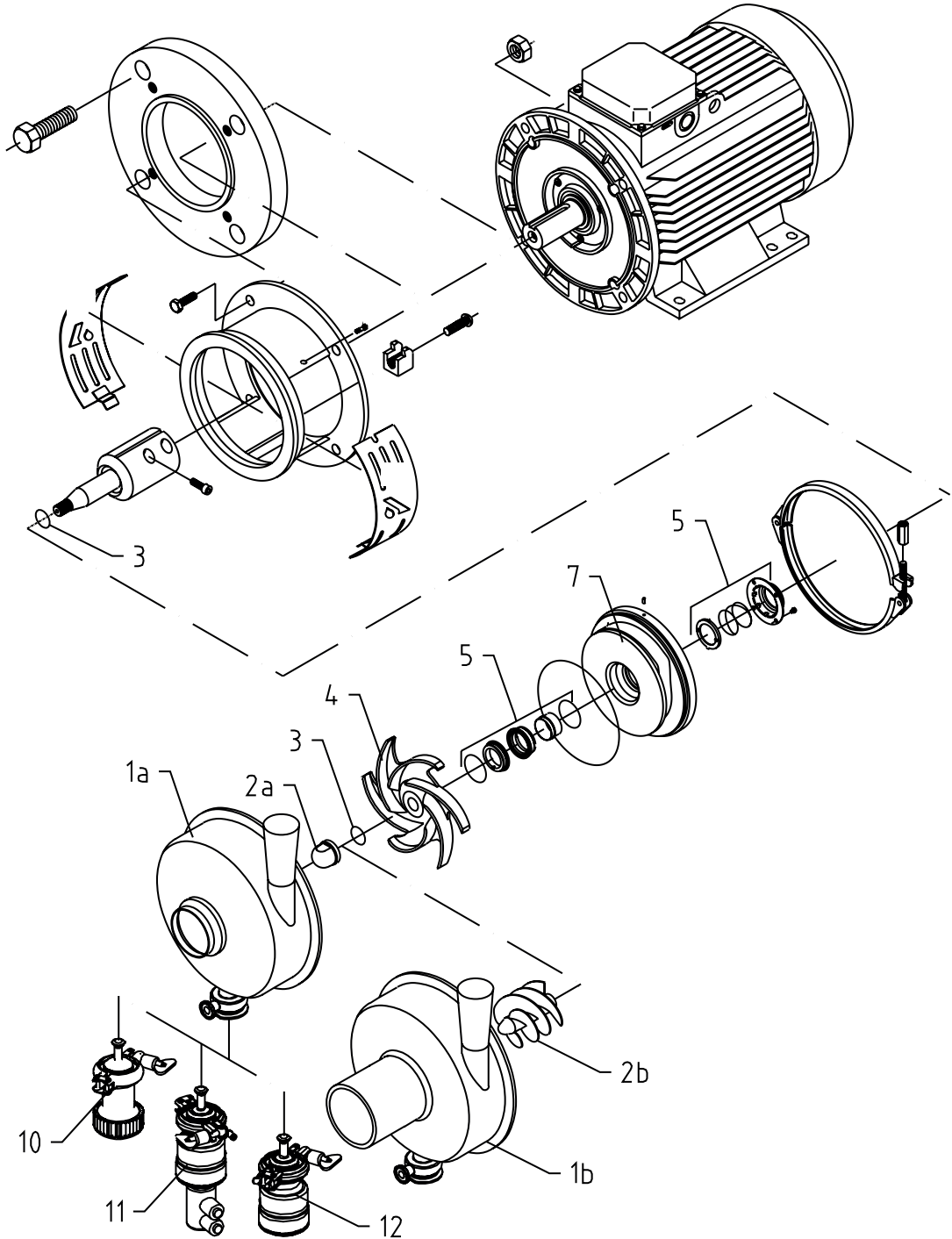

2. Spare Parts - W+ pump with AP1-valve

2.1 Overview

Item	Qty.	Description	Pump type			
			W+50/8	W+55/35	W+55/60	W+70/40
			Part no.			
1a	1	Pump housing	L284001	L284007	L284005	L284003
1b	1	Inducer housing	---	L284008	L284009	L284010
2a	1	Cap nut	L274747	L274748	L274749	L274749
2b	1	Inducer	---	L282060	L282063	L282062
3	1	O-rings kit EPDM USP Class VI 121°C	L810766	L810767	L810765	L810771
7	1	Backplate	L278229	L278230	L278231	L278234
10	1	Insert AP1-H Manual actuated	H330027			
11	1	Insert AP1-NC Air-actuated with PSH-unit	H330029			
12	1	Insert AP1-NC Air-actuated	H330028			

Items 4, 5 see page 6-7

Adjustable Feet see page 8-9

All other components see W+ standard spare parts list

2.2 Impeller

Impeller Ø Item 4	Pump type			
	W+50/8	W+55/35	W+55/60	W+70/40
Part no.				
Ø240				L278628
Ø235				L278629
Ø230				L278630
Ø225				L278631
Ø220			L278600	L278632
Ø215			L278601	L278633
Ø210		L278711	L278602	L278634
Ø205		L278712	L278603	L278635
Ø200	L278698	L278713	L278604	L278636
Ø195	L278699	L278714	L278605	L278637
Ø190	L278700	L278715	L278606	L278638
Ø185	L278701	L278716	L278607	
Ø180	L278702	L278717	L278608	
Ø175	L278703	L278718	L278609	
Ø170	L278704	L278719	L278610	
Ø165	L278705	L278720	L278611	
Ø160	L278706	L278721	L278612	
Ø155	L278707	L278722		
Ø150	L278708			
Ø145	L278709			
Ø140	L278710			

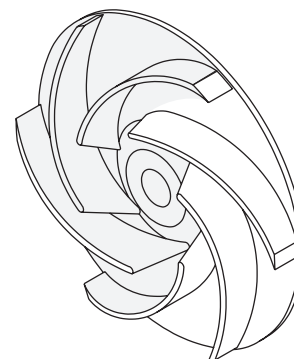

W+50/8

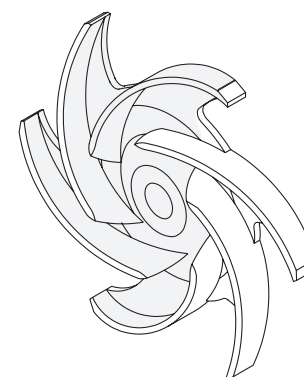

W+55/35, W+55/60, W+70/40

2. Spare Parts - W+ pump with AP1-valve

2.3 Shaft Seal

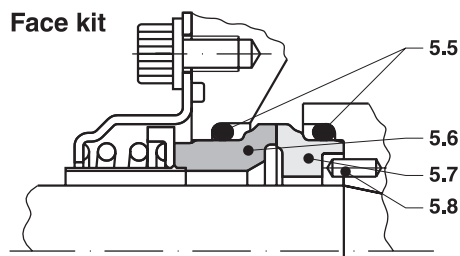
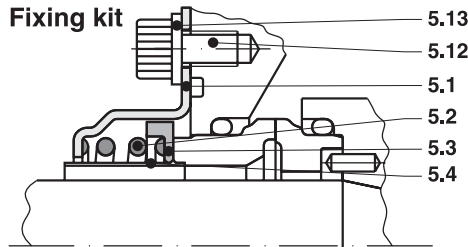
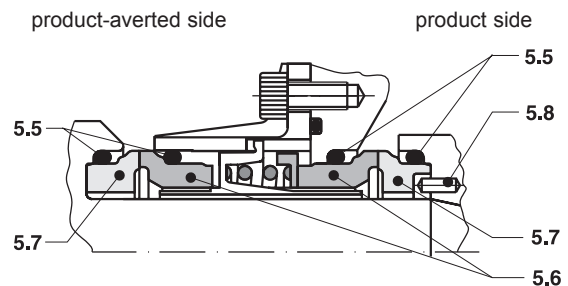
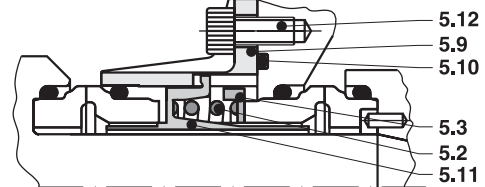
A. Single Seal Ø25+Ø35

B. Double Seal Ø25+Ø35

					Shaft size	
					Ø25 W+50/8 W+55/35	Ø35 W+55/60 W+70/40
Fixing kit - Item 5						
Seal type	Item	Description	Material	Part no.		
A	Single Seal	Complete		L772460	L772465	
		5.1 Seal housing 5.2 Spring 5.3 Pressure ring 5.4 Drain pipe	AISI 316 AISI 316 AISI 316 PTFE	(L773100)	(L773101)	
B	Double seal	Complete		L194448	L194449	
		5.2 Spring 5.3 Pressure ring 5.9 Seal housing 5.11 Pressure ring Union elbow	AISI 316 AISI 316 AISI 316 AISI 316 -			
	5.10	O-ring	EPDM	L772470	L771362	
	5.12	4 Screws M6x10	AISI 316	L770496	L770496	
	5.13*	4 Washers M6 (only W+50/8)	AISI 316	L701477	- - - -	
Face kit - Item 5					Ø25	Ø35
Seal type	Item	Description	Material	Part no.		
Product side	5.7	Complete Rotary seal face	SiC G	L810463	L810468	
	5.6	Stationary seal face	SiC G			
	5.8	Pin	AISI 316L			
	5.5	2 off o-rings	EPDM USP class VI 121°C			
Product-averted side	5.7	Complete Rotary seal face	SiC G	L810461	L810466	
	5.6	Stationary seal face	Carbon			
	5.8	Pin	AISI 316L			
	5.5	2 off o-rings	EPDM USP class VI 121°C			

2. Spare Parts - W+ pump with AP1-valve

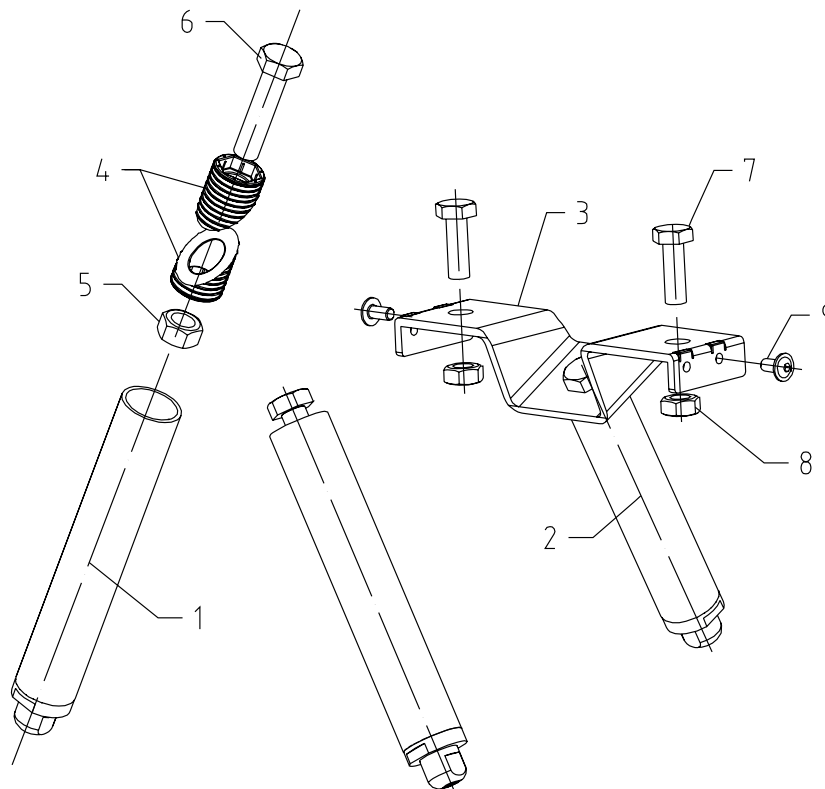
2.4 Adjustable Feet Motor 90-132



			Motor			
			90	100	112	132
			Centre height 350			
Item	Qty.	Description	Part no.			
-	-	Complete frame	L808816	L808815	L808514	L808905
1	2	Leg front, complete	L809261	L809261	L809261	L809261
2	1	Leg back, complete	L809182	L809181	L809180	L809153
3	1	Frame	L282484	L282485	L282487	L282487
4	6	Split bushing	L282473	L282473	L282473	L282473
5	3	Nut	L700242	L700242	L700242	L700242
6	3	Screw	L701981	L701981	L701981	L701981
7	2	Screw	L701380	L701380	L701380	L700238
8	2	Nut	L700864	L700864	L700864	L700242
9	2	Screw, flanged head	L700420	L700420	L700420	L700420

2. Spare Parts - W+ pump with AP1-valve

2.5 Adjustable Feet Motor 160-200

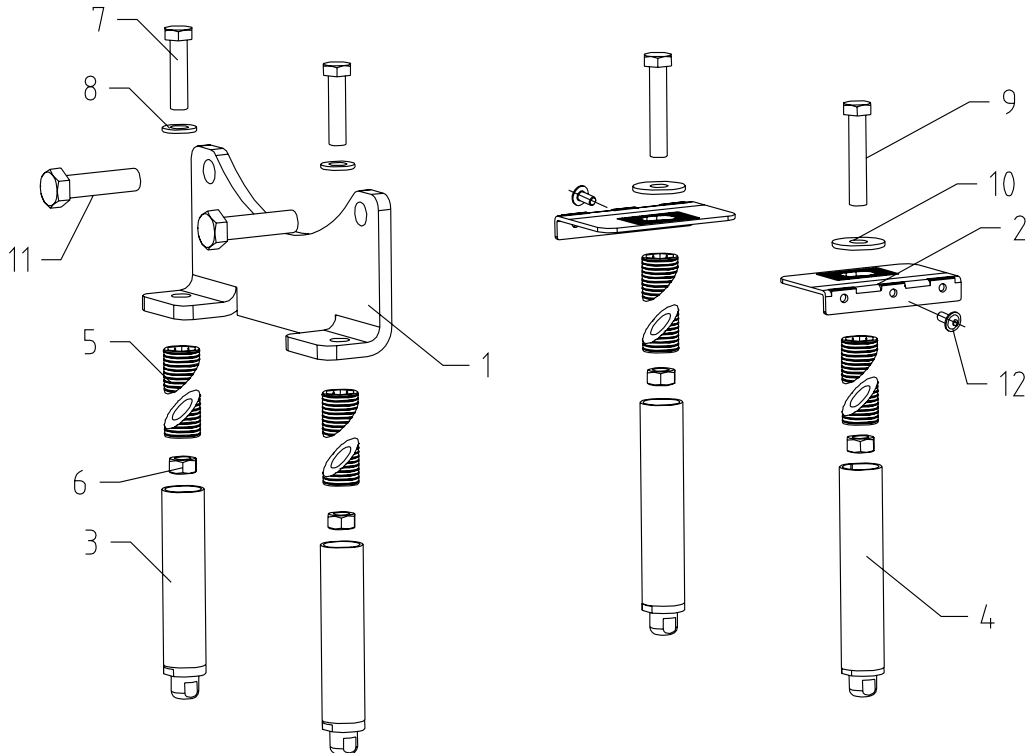

			Motor		
			160	180	200
			Centre height 350		
Item	Qty.	Description	Part no.		
-	-	Complete frame	L808808	L808810	L808813
1	1	Frame for front leg	L279962	L279962	L279963
2	2	Angle plate	L282488	L282488	----
2	1	Angle plate, R	----	----	L808709
2	1	Angle plate, L	----	----	L808710
3	4	Leg, complete	L809061	----	L809066
3	2	Leg front, complete	----	L809066	----
4	2	Leg back, complete	----	L809049	----
5	8	Split bushing	L282473	L282473	L282473
6	4	Nut	L700242	L700242	L700242
7	2	Screw	L703141	L703141	L703141
8	2	Washer	L701475	L701475	L701475
9	2	Screw	L771697	L771697	L771698
10	2	Washer	L781058	L781058	L781058
11	2	Screw	L701474	L701474	L701553
12	2	Screw, flanged head	L700420	L700420	L700420

W+

CENTRIFUGAL PUMP



SPX Flow Technology Poland sp. z o.o.

Hermana Frankego 9
85-862 Bydgoszcz, Poland
P: (+48) 52 525 9900
F: (+48) 52 525 9909

SPX reserves the right to incorporate the latest design and material changes without notice or obligation.

Design features, materials of construction and dimensional data, as described in this bulletin, are provided for your information only and should not be relied upon unless confirmed in writing. Please contact your local sales representative for product availability in your region. For more information visit www.spx.com.

ISSUED 10/2012 - Original Manual
COPYRIGHT ©2011 SPX Corporation

www.sks-online.com